

400-102 Square Road Stud - Smooth

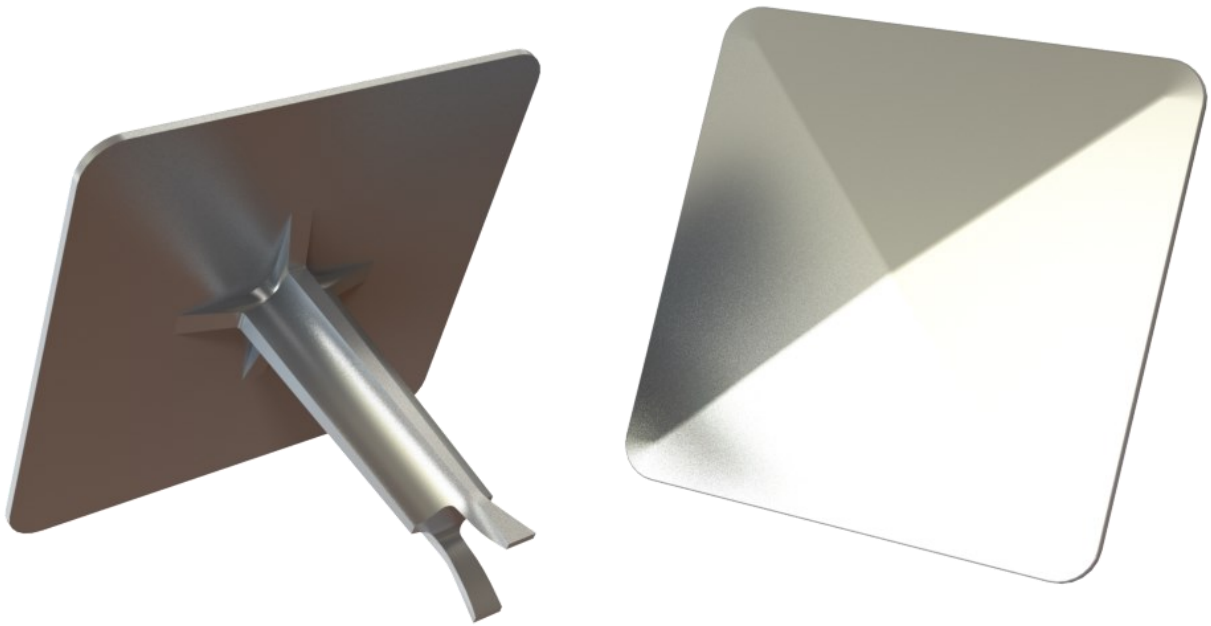

Above. Shown with polished finish

Description

Manufactured from Aluminium.
Satin polish finish as standard.
Constructed from non corrosive material. Long Service life. Comes with a bevelled top.

Dimensions

100mm x 100mm x 75mm wall thickness

Options

Ribbed topped version suitable for off-highway use such as car parks
Stainless steel
Full Installation Service

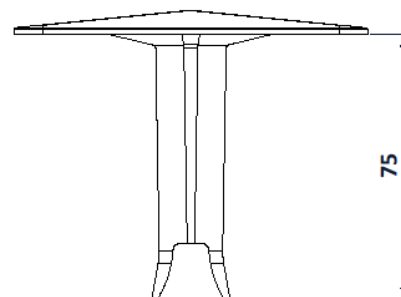
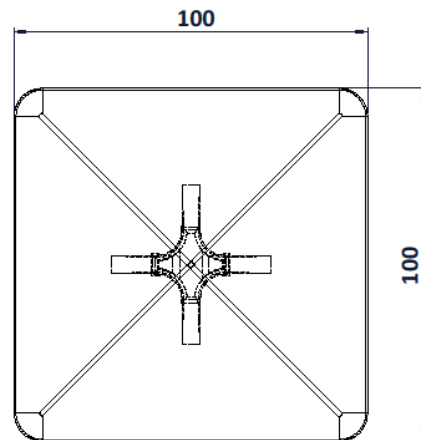

400-102 Square Road Stud - Smooth

Installation

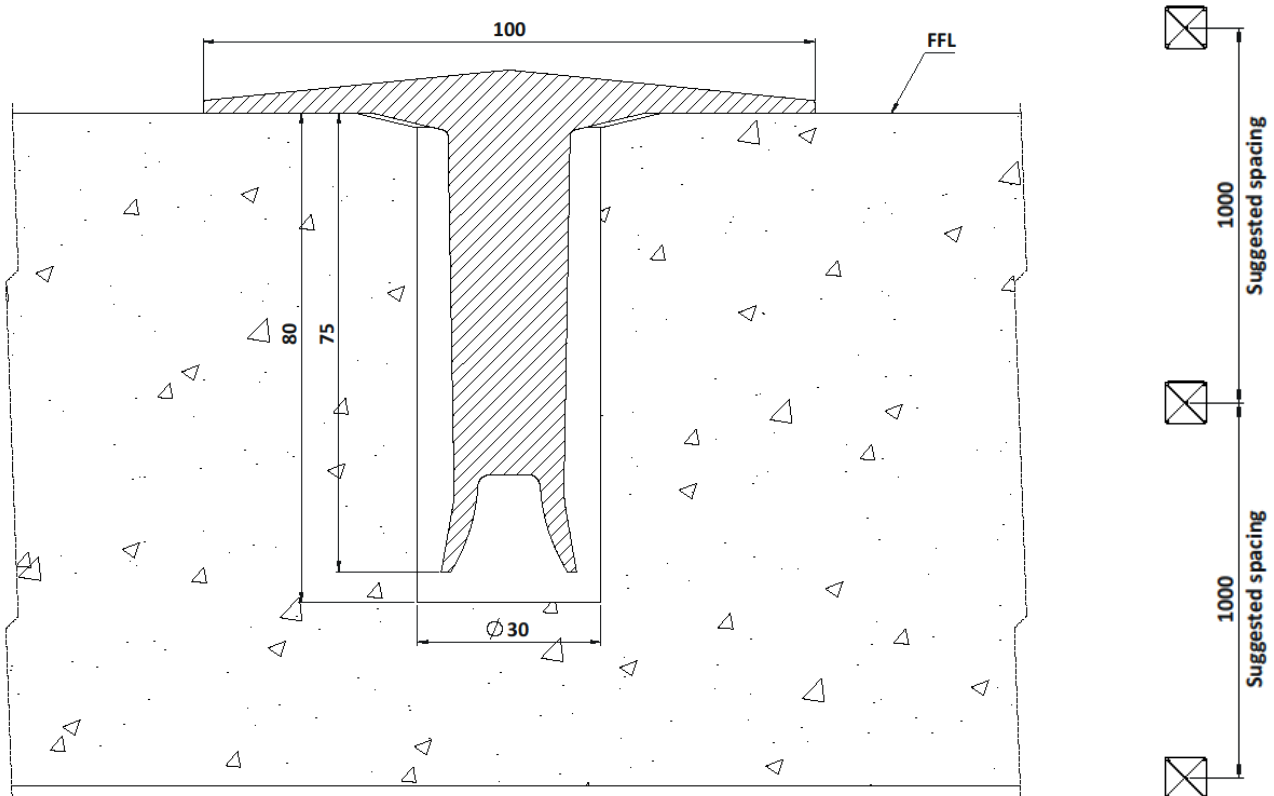

Installation

1. Drill a hole 30mm in diameter to a depth of 80mm which should allow the crossing stud to sit level on the surface.
2. Remove dust and debris caused by drilling.
3. Following the product guidelines heat the Polymer Modified Adhesive and pour a sufficient amount to fill the drilled hole.
4. Push the stud into the hole firmly ensuring an edge seal around the entire stud
5. Allow a few minutes for the Polymer Modified Adhesive to set, if stud cannot rotate using hand and finger rotation the stud is ready for trafficking.

Cleaning & Maintenance

This product is designed for all weather exposure requiring only minimal maintenance as detailed below.

Aluminium: Manufactured from premium grade aluminium. Maintenance free, inspect fixing every 6 months. Add additional Adhesive where required.

400-102 Square Road Stud - Smooth

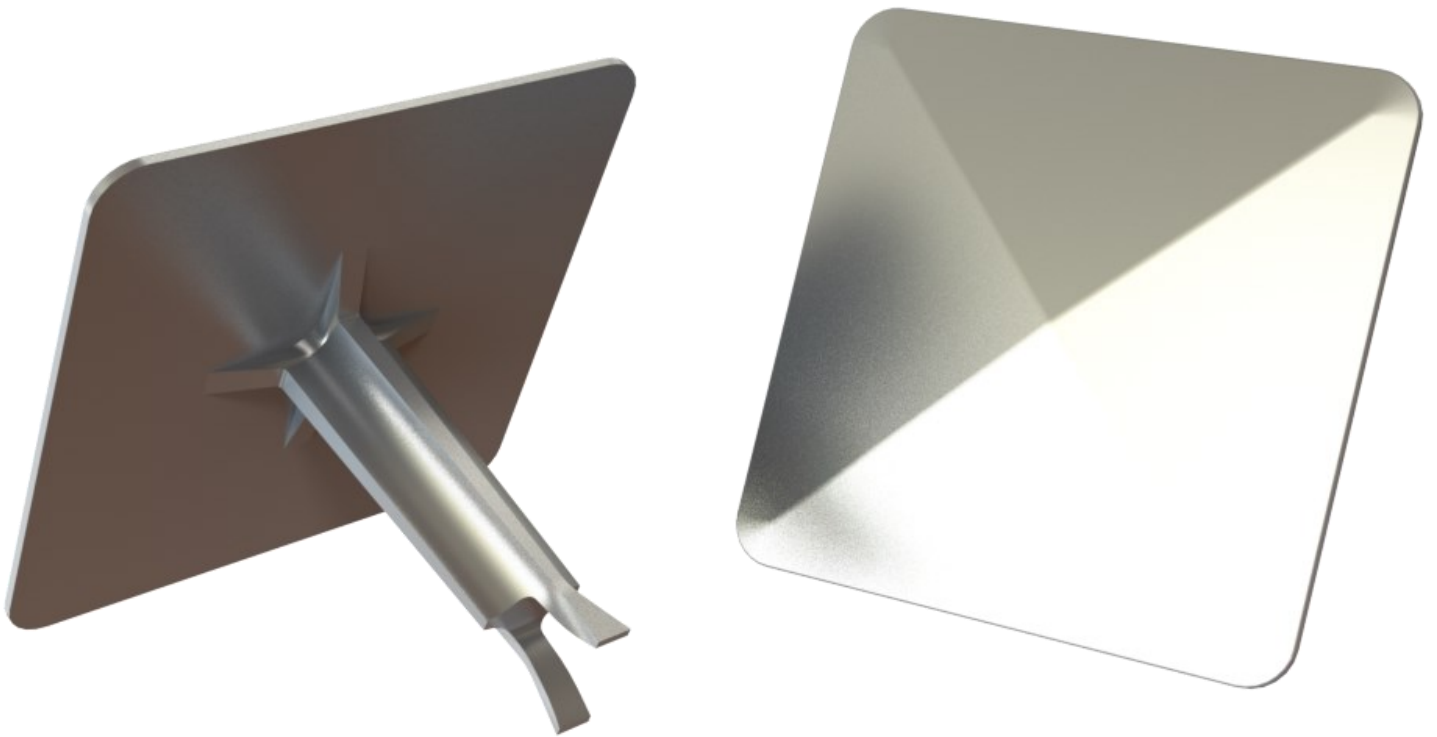

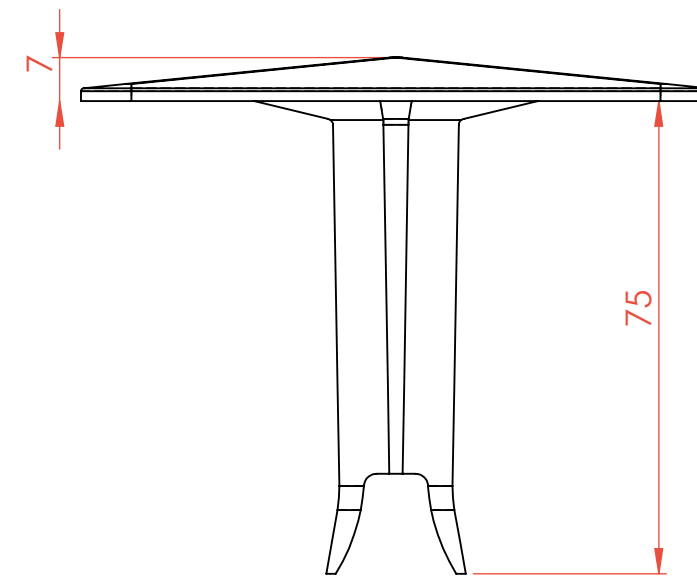
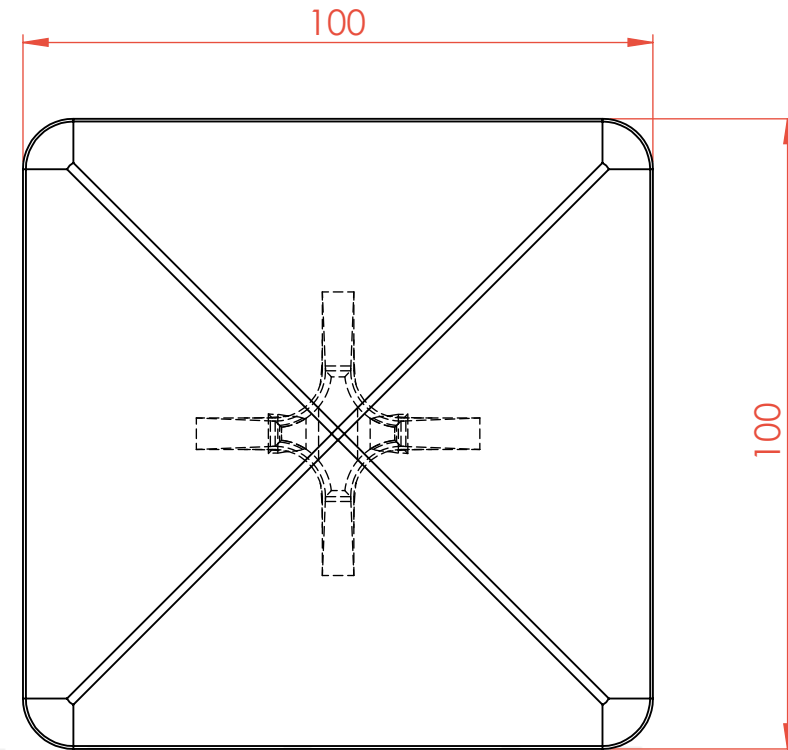
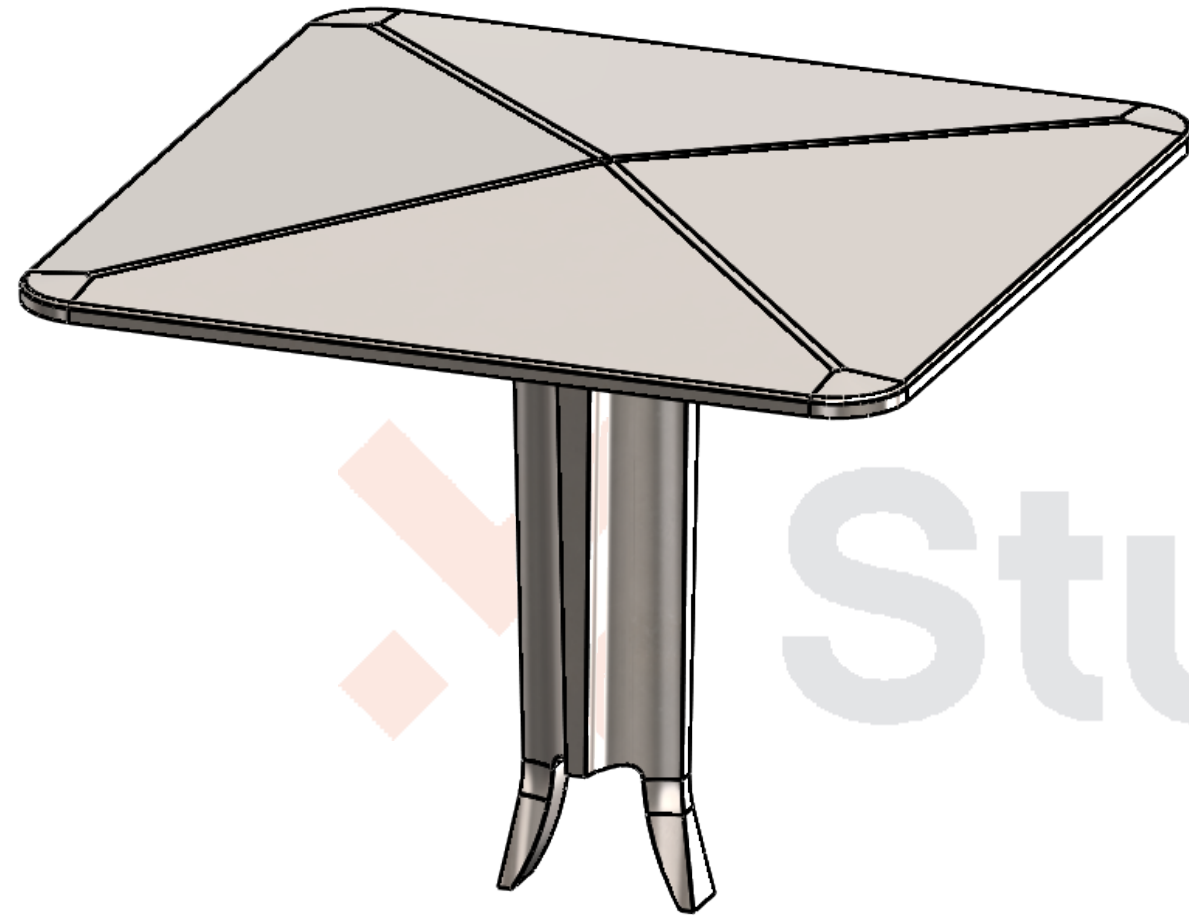

Studmarc

Manufactured from Aluminium
Satin polished finish

All details are indicative and must be checked with site engineer for approval.
This plan is based on general advice and will need to be checked against local planning regulations/requirements.
Drawing copyright property of Studmarc and must not be duplicated or distributed to third parties without consent.

Date Issued	Drawn By	TS	 <p>Studmarc</p> <p>Trefeglwys Road Caersws Powys SY17 5HH</p> <p>Tel: 01686 689 198 sales@studmarc.com</p>
Customer	Checked By		
Project	Scale	1:1	
Title	Sheet Size	A3	
	All Dimensions in mm Do not scale from drawing If in doubt please ask!		
Drg No.	Issue. 1		
Title		400-102 100mm Road Stud - Smooth	