

400-302 Square Road Stud - Serrated - Chisel

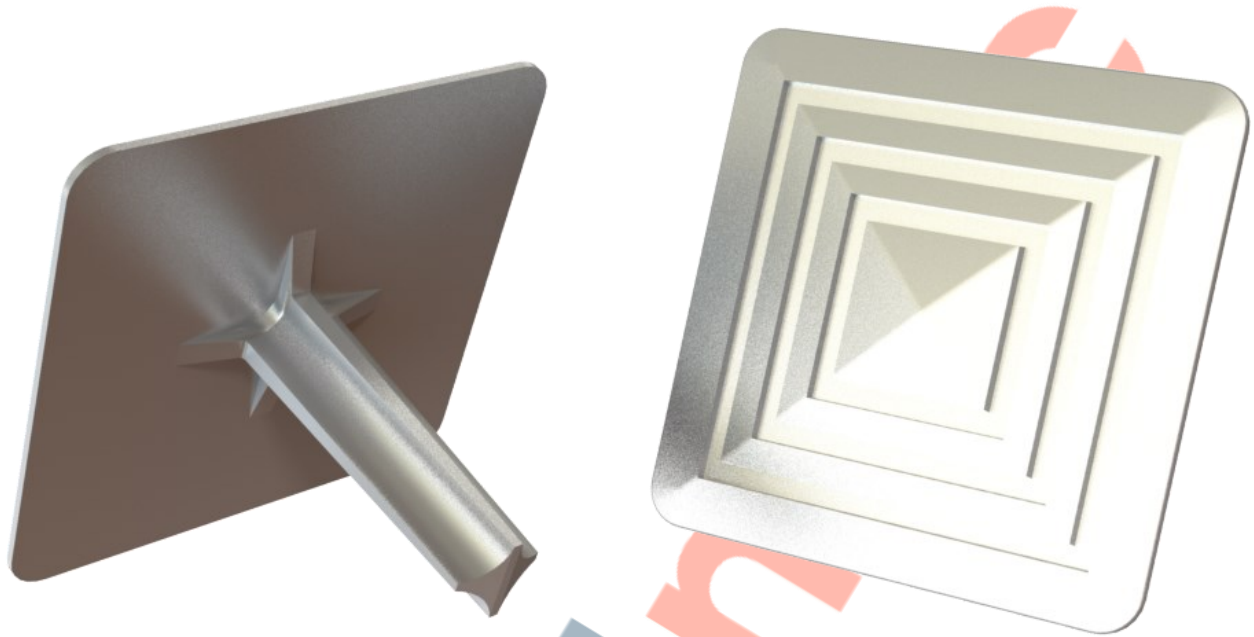

Above. Shown with satin polish finish

Description

Manufactured from Stainless steel. Satin polish finish as standard. Constructed from non corrosive material. Long Service life. Comes with a bevelled top. Serrated top.

Dimensions

100mm x 100mm x 70mm

Options

Smooth topped version suitable for off-highway use such as car parks

Aluminium Version

Ribbed version

Full installation service

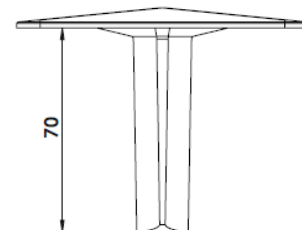
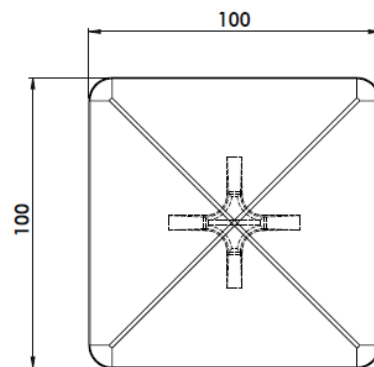

400-302 Square Road Stud - Serrated - Chisel

Installation

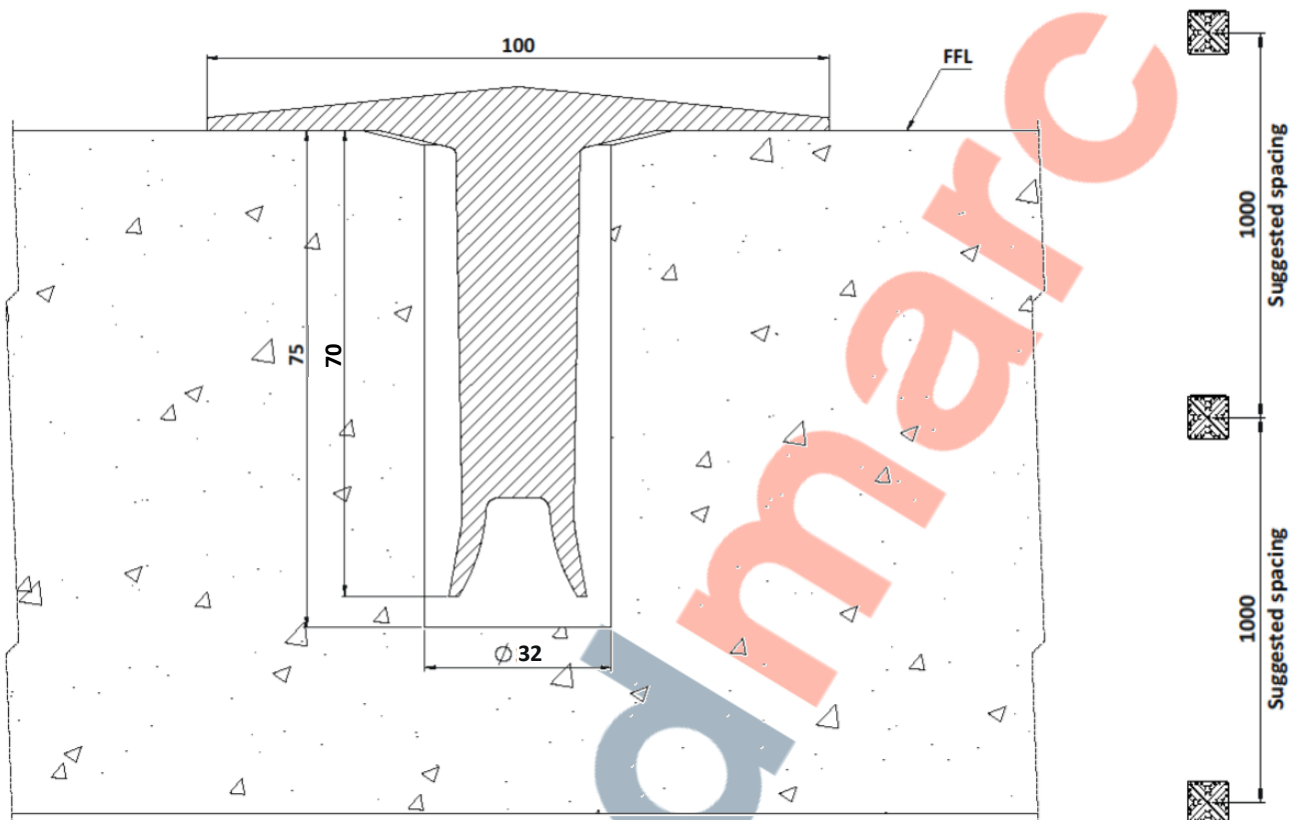

Installation

1. Drill a hole 32mm in diameter to a depth of 75mm which should allow the crossing stud to sit level on the surface.

Note: for concrete surfaces it is necessary to prime the hole and surrounding road surface with bitumen emulsion primer prior to grouting.

2. Fill the hole fully with hot bitumen grout and IMMEDIATELY insert the marker shank and firmly press the head to the road surface taking care that the marker is properly aligned.

3. If necessary, pressing may be supplemented by light tamping with a wood or rubber headed mallet or similar. ON NO ACCOUNT SHOULD THE STUD BE HAMMERED.

4. The surplus of bitumen will be forced out of the hole by the ingoing shank to form a bed for the head. Any surplus bitumen beyond the area of the marker should be trimmed off.

Cleaning & Maintenance

This product is designed for all weather exposure requiring only minimal maintenance as detailed below.

Stainless Steel: Manufactured from Stainless steel. Maintenance free, inspect fixing every 6 months.

Add additional Adhesive where required.

DATASHEET

400-302 Square Road Stud - Serrated - Chisel

