

316L ST Stainless Steel Stud

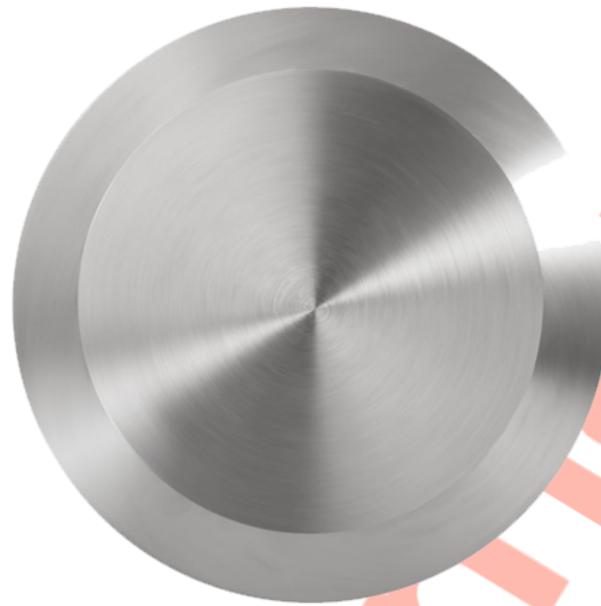

Above. Shown with machined

Description

Manufactured from 316L Stainless Steel.
Machined polish finish as standard.
Constructed from non corrosive material.
Long Service life. To be installed onto finished surfaces.

Dimensions

D1: 25mm \varnothing D2: 15mm \varnothing x 5mm thick top
M6 x 15mm welded pin
M6 x 12mm machined pin

Options

Sizes 15, 25, 30 & 35mm

Material Options:

Brass - Aluminium - Bronze - 304 S/S

Fixing Pin Options

Self adhesive - Welded pin - Machined pin -

No pin

Full installation service

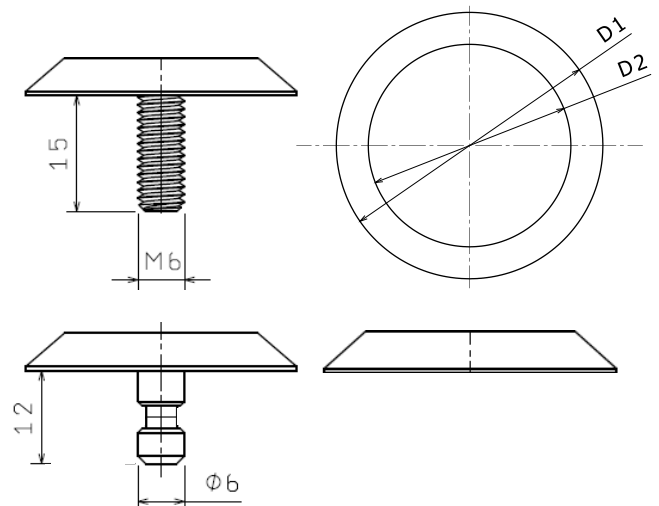

ST Stainless Steel Stud

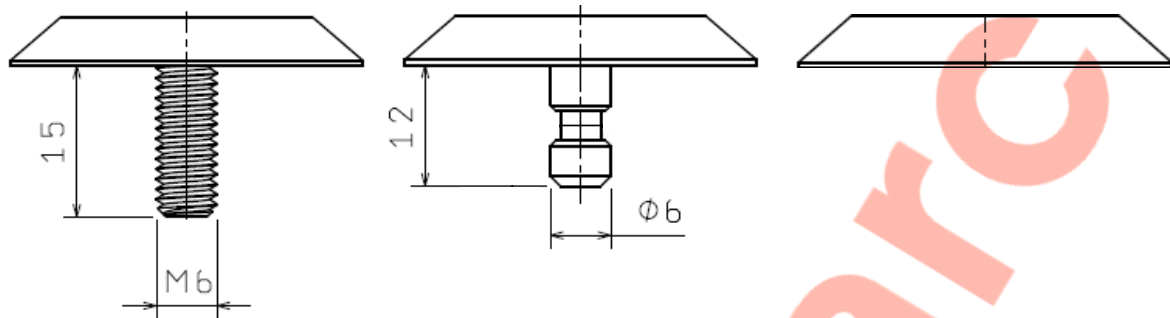

Installation Welded Pin

1. Drill holes 7mm dia x 16mm depth.
2. Remove dust and debris caused by drilling.
3. Following the product guidelines, screw the nozzle on, and press the trigger - the two part resin will mix in the nozzle. Pour a sufficient amount to fill the drilled hole.
4. Push the stud into the hole firmly ensuring an edge seal around the entire stud
5. Allow a few minutes for the Polymer Modified Adhesive to set.

Installation Machined Pin

1. Drill holes 7mm dia x 13mm depth.
2. Remove dust and debris caused by drilling.
3. Following the product guidelines, screw the nozzle on, and press the trigger - the two part resin will mix in the nozzle. Pour a sufficient amount to fill the drilled hole.
4. Push the stud into the hole firmly ensuring an edge seal around the entire stud
5. Allow a few minutes for the Polymer Modified Adhesive to set.

Installation Self Adhesive

1. Prep area where stud is to be situated by using a grease and dirt remover, i.e white spirits. Then let dry thoroughly.
2. Once area is dried, peel backing to stud off and press down firmly.

Note: We highly recommend only using the self-adhesive studs on tiled floors.

For layout suggestions please refer to the below.

<https://www.studmarc.com/knowledge-base/how-far-apart-should-tactile-studs-be-installed-from-each-other/>